

MLX92232

End of Line programmable 3-Wire Hall Effect Latch/Switch

Datasheet

1 Features and Benefits

- Programmable parameters in application:
 - Wide magnetic Latch range: $\pm 0.4\text{mT}$ to $\pm 80\text{mT}$
 - Wide magnetic Switch range: $\pm 1.5\text{mT}$ to $\pm 66\text{mT}$
 - Programmable Hysteresis: 1mT to 36mT
 - Programmable Active Pole: North or South
 - Programmable Output Behaviour: Direct or Inverted
- Increased Traceability: 32 bits ID on chip
- Built-in Negative TC coefficient: 0 to -2000 ppm/ $^{\circ}\text{C}$
- Wide operating voltage range: from 2.7V to 24V
- Reverse Supply Voltage Protection
- Output Current Limit with Auto-Shutoff
- Under-Voltage Lockout Protection
- Thermal Protection
- Lateral Sensitivity option
- Dual die option

2 Application Examples

- Automotive, Consumer and Industrial
- Solid-state switch
- 3-phase BLDC motor commutation
- Wiper motor
- Window lifter
- Sunroof/Tailgate opener
- Seat motor adjuster
- Electrical power steering
- Brake Light switch

3 Ordering Information

Product Code	Temperature Code	Package Code	Comment
MLX92232LSE-AAA-000-RE	L (-40°C to 150°C)	SE (TSOT-3L)	3-wire Switch/Latch, TC=0 ppm/ $^{\circ}\text{C}$
MLX92232LUA-AAA-000-BU	L (-40°C to 150°C)	UA (TO92-3L)	3-wire Switch/Latch, TC=0 ppm/ $^{\circ}\text{C}$
MLX92232LVA-AAA-000-BU	L (-40°C to 150°C)	VA (SIP 4L)	Dual Die 3-wire Switch/Latch, TC=0 ppm/ $^{\circ}\text{C}$
MLX92232LSE-AAA-001-RE	L (-40°C to 150°C)	SE (TSOT-3L)	3-wire Switch/Latch, TC=-400 ppm/ $^{\circ}\text{C}$
MLX92232LUA-AAA-001-BU	L (-40°C to 150°C)	UA (TO92-3L)	3-wire Switch/Latch, TC=-400 ppm/ $^{\circ}\text{C}$
MLX92232LSE-AAA-002-RE	L (-40°C to 150°C)	SE (TSOT-3L)	3-wire Switch/Latch, TC=-1100 ppm/ $^{\circ}\text{C}$
MLX92232LUA-AAA-002-BU	L (-40°C to 150°C)	UA (TO92-3L)	3-wire Switch/Latch, TC=-1100 ppm/ $^{\circ}\text{C}$
MLX92232LSE-AAA-003-RE	L (-40°C to 150°C)	SE (TSOT-3L)	3-wire Switch/Latch, TC=-2000 ppm/ $^{\circ}\text{C}$
MLX92232LUA-AAA-003-BU	L (-40°C to 150°C)	UA (TO92-3L)	3-wire Switch/Latch, TC=-2000 ppm/ $^{\circ}\text{C}$
MLX92232LSE-AAA-200-RE	L (-40°C to 150°C)	SE (TSOT-3L)	3-wire Switch/Latch IMC version, TC=0 ppm/ $^{\circ}\text{C}$
MLX92232LSE-AAA-201-RE	L (-40°C to 150°C)	SE (TSOT-3L)	3-wire Switch/Latch IMC version, TC=-400 ppm/ $^{\circ}\text{C}$
MLX92232LSE-AAA-202-RE	L (-40°C to 150°C)	SE (TSOT-3L)	3-wire Switch/Latch IMC version, TC=-1100 ppm/ $^{\circ}\text{C}$
MLX92232LSE-AAA-203-RE	L (-40°C to 150°C)	SE (TSOT-3L)	3-wire Switch/Latch IMC version, TC=-2000 ppm/ $^{\circ}\text{C}$
MLX92232LUA-AAA-200-BU	L (-40°C to 150°C)	UA (TO92-3L)	3-wire Switch/Latch IMC version, TC=0 ppm/ $^{\circ}\text{C}$

4 Functional Diagram

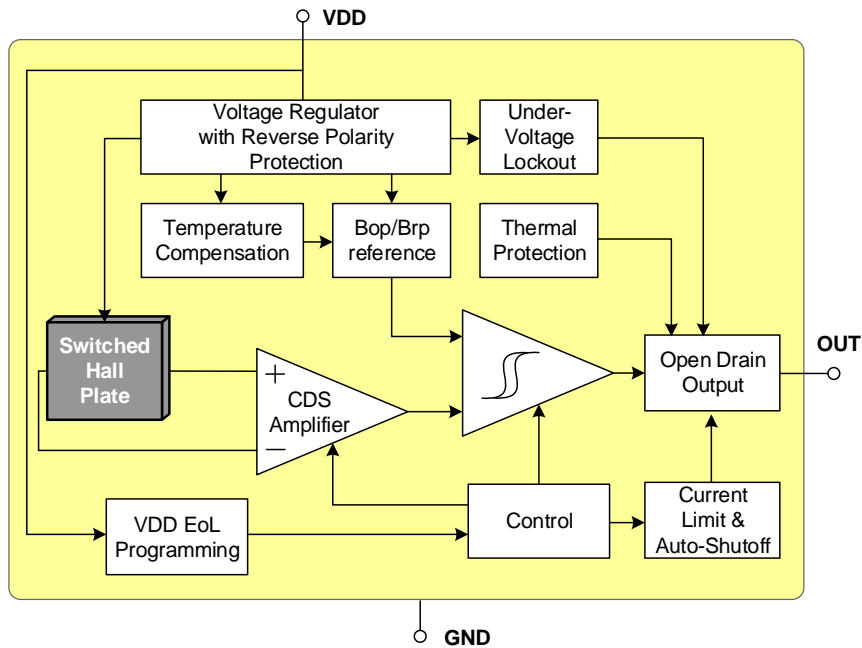

5 General Description

The Melexis MLX92232 is the second generation programmable Hall-effect sensor designed in mixed signal CMOS technology. The device integrates a voltage regulator, Hall sensor with advanced offset cancellation system and an open-drain output driver, all in a single package.

With the built-in reverse voltage protection, a serial resistor or diode on the supply line is not required so that even remote sensors can be specified for low voltage operation down to 2.7V while being reverse voltage tolerant. In the event of a drop below the minimum supply voltage during operation, the under-voltage lock-out protection will automatically freeze the device, preventing the electrical perturbation to affect the magnetic measurement circuitry.

The open drain output is fully protected against short-circuit with a built-in current limit. An additional automatic output shut-off is activated in case of a prolonged short-circuit condition. A self-check is then periodically performed to switch back to normal operation if the short-circuit condition is released.

The on-chip thermal protection also switches off the output if the junction temperature increases above an abnormally high threshold. It will automatically recover once the temperature decreases below a safe value.

Furthermore the MLX92232 features a full set of programmable parameters that can be adjusted in the application in order to achieve the highest possible system accuracy by compensating the mechanical tolerances.

An Integrated Magnetic Concentrator option (IMC) has been added to sense the lateral field component. This is adding more flexibility in the module design. A dual die option is also available for applications that need a secondary output; these can be programmed independently from each other.

Table of Contents

1	Features and Benefits	1
2	Application Examples	1
3	Ordering Information	1
4	Functional Diagram	2
5	General Description	2
6	Glossary of Terms	4
7	Absolute Maximum Ratings	4
8	General Electrical Specifications	5
9	Magnetic Specifications	6
10	Programming parameters	7
10.1	Latch Sensor.....	9
10.2	Switch Sensor.....	10
11	Application Information	11
11.1	Typical Three-Wire Application Circuit.....	11
11.2	Automotive and Harsh, Noisy Environments Three-Wire Circuit.....	12
12	Package Information	13
12.1	TSOT-3L (SE Package).....	13
12.2	TO92-3L (UA Package).....	15
12.3	VA Package.....	17
13	IC handling and assembly	19
13.1	Storage and handling of plastic encapsulated ICs.....	19
13.2	Assembly of encapsulated ICs.....	19
13.3	Environment and sustainability.....	19
14	Disclaimer	20

MLX92232

End of Line programmable 3-Wire Hall Effect Latch/Switch

Datasheet

6 Glossary of Terms

Tesla	Units for the magnetic flux density, 1 mT = 10 Gauss
TC	Temperature Coefficient in ppm/°C
IMC	Integrated Magnetic Concentrator
POR	Power on Reset

7 Absolute Maximum Ratings

Exceeding the absolute maximum ratings may cause permanent damage. Exposure to absolute maximum rated conditions for extended periods may affect device reliability.

Parameter	Symbol	Value	Units
Supply Voltage ^(1, 2)	V _{DD}	+27	V
Supply Voltage (Load Dump) ^(1, 4)	V _{DD}	+32	V
Supply Current ^(1, 2, 3)	I _{DD}	+20	mA
Supply Current ^(1, 3, 4)	I _{DD}	+50	mA
Reverse Supply Voltage ^(1, 2)	V _{DDREV}	-24	V
Reverse Supply Voltage ^(1, 4)	V _{DDREV}	-30	V
Reverse Supply Current ^(1, 2, 5)	I _{DDREV}	-20	mA
Reverse Supply Current ^(1, 4, 5)	I _{DDREV}	-50	mA
Output Voltage ^(1, 2)	V _{OUT}	+27	V
Output Current ^(1, 2, 5)	I _{OUT}	+20	mA
Output Current ^(1, 4, 6)	I _{OUT}	+75	mA
Reverse Output Voltage ⁽¹⁾	V _{OUTREV}	-0.5	V
Reverse Output Current ^(1, 2)	I _{OUTREV}	-100	mA
Maximum Junction Temperature ⁽⁷⁾	T _J	+165	°C
Storage Temperature Range	T _S	-55 to +165	°C
ESD Sensitivity – HBM ⁽⁸⁾	-	4000	V
ESD Sensitivity – CDM ⁽⁹⁾	-	1000	V
Magnetic Flux Density	B	Unlimited	mT

¹ The maximum junction temperature should not be exceeded

² For maximum 1 hour

³ Including current through protection device

⁴ For maximum 500ms

⁵ Through protection device

⁶ For V_{OUT} ≤ 27V

⁷ For 1000 hours

⁸ Human Model according AEC-Q100-002 standard

⁹ Charged Device Model according AEC-Q100-011 standard

8 General Electrical Specifications

DC Operating Parameters $V_{DD} = 2.7V$ to $24V$, $T_A = -40^{\circ}C$ to $150^{\circ}C$ (unless otherwise specified)

Parameter	Symbol	Test Conditions	Min	Typ ⁽¹⁾	Max	Units
Supply Voltage	V_{DD}	Operating	2.7	-	24	V
Supply Current ⁽²⁾	I_{DD}		1.5	3.0	4.5	mA
Supply Current ⁽³⁾	I_{DD}		3.0	6.0	9.0	mA
Reverse supply current	I_{DDREV}	$V_{DD} = -16V$	-1	-	-	mA
Output Saturation Voltage	V_{DSON}	$V_{DD} = 3.5$ to $24V$, $I_{OUT} = 20mA$	-	0.3	0.5	V
Output Leakage	I_{OFF}	$V_{OUT} = 12V$, $V_{DD} = 12V$	-	-	10	μA
Output Rise Time ^(4, 8) (R_{PU} dependent)	t_R	$R_{PU} = 1k\Omega$, $V_{DD} = 12V$, $V_{PU} = 5V$ $C_{LOAD} = 50pF$ to GND	0.1	0.3	1	μs
Output Fall Time ^(4, 8) (On-chip controlled)	t_F	$R_{PU} = 1k\Omega$, $V_{DD} = 12V$, $V_{PU} = 5V$ $C_{LOAD} = 50pF$ to GND	0.1	0.3	1	μs
Power-On Time ^(5, 6, 9)	t_{ON}	$V_{DD} = 5V$, $dV_{DD}/dt > 2V/\mu s$	-	40	70	μs
Power-On Output State	-	$t < t_{ON}$	High (V_{PU})			-
Output Current Limit	I_{CL}	$V_{DD} = 3.5$ to $24V$, $V_{OUT} = 12V$	25	40	70	mA
Output ON Time under Current Limit conditions ⁽¹⁰⁾	t_{CLON}	$V_{PU} = 12V$, $R_{PU} = 100\Omega$	150	240	-	μs
Output OFF Time under Current Limit conditions ⁽¹⁰⁾	t_{CLOFF}	$V_{PU} = 12V$, $R_{PU} = 100\Omega$	-	3.5	-	ms
Chopping Frequency	f_{CHOP}		-	340	-	kHz
Refresh Period	t_{PER}		-	6	-	μs
Output Jitter (p-p) ⁽⁴⁾	t_{JITTER}	Over 1000 successive switching events @10kHz triangle wave magnetic field, $B > \pm(B_{OPMAX} + 20mT)$	-	± 3.2	-	μs
Maximum Switching Frequency ^(4, 7)	f_{SW}	$B > \pm 3(B_{OPMAX} + 1mT)$, triangle wave magnetic field	30	65	-	kHz
Under-voltage Lockout Threshold	V_{UVL}		-	-	2.7	V
Under-voltage Lockout Reaction time ⁽⁴⁾	t_{UVL}		-	1	-	μs
Thermal Protection Threshold	T_{PROT}	Junction temperature	-	190 ⁽¹¹⁾	-	$^{\circ}C$
Thermal Protection Release	T_{REL}	Junction temperature	-	180 ⁽¹¹⁾	-	$^{\circ}C$
SE Package Thermal Resistance	R_{THJA}	Single layer PCB, JEDEC standard test boards		300		$^{\circ}C/W$
UA package Thermal Resistance	R_{THJA}	Single layer PCB, JEDEC standard test boards		200		$^{\circ}C/W$
VA package Thermal Resistance	R_{THJA}	Single layer PCB, JEDEC standard test boards		105		$^{\circ}C/W$

1 Typical values are defined at $T_A = +25^{\circ}C$ and $V_{DD} = 12V$

2 Valid for 92232LSE-AAA-xxx and 92232LUA-AAA-xxx versions

3 Valid for 92232LVA-AAA-xxx version

4 Guaranteed by design and verified by characterization, not production tested

5 The Power-On Time represents the time from reaching $V_{DD} = 2.7V$ to the first refresh of the output

6 Power-On Slew Rate is not critical for the proper device start-up.

7 Maximum switching frequency corresponds to the maximum frequency of the applied magnetic field which is detected without loss of pulses

8 R_{PU} and V_{PU} are respectively the external pull-up resistor and pull-up power supply

9 Activated output with 1 mT overdrive

10 If the Output is in Current Limitation longer than t_{CLON} the Output is switched off in high-impedance state. The Output returns back in active state at next reaching of B_{OP} or after t_{CLOFF} time interval

11 T_{PROT} and T_{REL} are the corresponding junction temperature values

9 Magnetic Specifications

DC Operating Parameters $V_{DD} = 2.7V$ to $24V$, $T_A = -40^{\circ}C$ to $150^{\circ}C$ (unless otherwise specified)

Parameter	Symbol	Test Conditions	Min	Typ ⁽¹⁾	Max	Units
Latch Threshold Programming Range ^(2, 3)	B _{LTH}	V _{DD} =12V, T _A =25°C	±0.4		±80	mT
Switch Operating Point Programming Range ^(3, 4)	B _{OP}	V _{DD} =12V, T _A =25°C	±1.5		±66	mT
Proportional Hysteresis Ratio Programming ^(5, 6)	HYS _{RATIO}	V _{DD} =12V, T _A =25°C	0.1		0.55	-
Fixed Hysteresis Value 0 ^(7, 8)	B _{FHYS0}		-	0	-	mT
Fixed Hysteresis Value 1 ^(7, 8)	B _{FHYS1}		-	1	-	mT
Fixed Hysteresis Value 2 ^(7, 8)	B _{FHYS2}		-	1.2	-	mT
Fixed Hysteresis Value 3 ^(7, 8)	B _{FHYS3}		-	1.4	-	mT
Fixed Hysteresis Value 4 ^(7, 8)	B _{FHYS4}		-	1.8	-	mT
Fixed Hysteresis Value 5 ^(7, 8)	B _{FHYS5}		-	2.2	-	mT
Latch Sensor Magnetic Offset ⁽⁹⁾	B _{OFFSET}	T _A =25°C	-0.5		0.5	mT
		T _A =-40°C to 150°C	-0.9		0.9	mT
Temperature Coefficient ⁽¹⁰⁾	TC	Latch with: No IMC: B _{OP} /B _{RP} = +- 28mT IMC: B _{OP} /B _{RP} = +- 12mT		0 -400 -1100 -2000		ppm/°C
Factory Programmed B _{OP} , Switch ⁽¹¹⁾	B _{OP}	V _{DD} =12V, T _A =25°C, target 28mT	26	28	30	mT
Factory Programmed B _{RP} , Switch ⁽¹¹⁾	B _{RP}	V _{DD} =12V, T _A =25°C, target 28mT, HYS _{RATIO} =0.25	19	21	23	mT
Factory Programmed B _{OP} , Latch ⁽¹²⁾	B _{OP}	V _{DD} =12V, T _A =25°C, target 12mT	10	12	14	mT
Factory Programmed B _{RP} , Latch ⁽¹²⁾	B _{RP}	V _{DD} =12V, T _A =25°C, target -12mT	-14	-12	-10	mT

1 The typical values are defined at T_A = 25°C and V_{DD} = 12V.

2 For Latch sensor B_{LTH}=(B_{OP}-B_{RP})/2. The Latch programming step is typically between 0.7% and 1.5% of the programmed B_{LTH} value for |B_{LTH}|≥1.2mT and 0.018mT for |B_{LTH}|≤1.2mT.

3 Guaranteed by design and verified by characterization. The programming ranges for BLTH and BOP include some margin for process deviations.

4 For Switch sensor the B_{OP} programming step is typically between 0.7% and 1.5% of the programmed B_{OP} value for |B_{OP}|≥4.8mT and 0.072mT for |B_{OP}|≤4.8mT.

5 For Switch sensor with proportional hysteresis HYS_{RATIO}=B_{HYS}/B_{OP}. The HYS_{RATIO} programming step is 0.05.

6 The given min/max limits are typical values.

7 For Switch sensor with fixed hysteresis value

8 Guaranteed by design and verified by characterization.

9 For Latch sensor offset is defined as B_{OFFSET} = (B_{OP}+B_{RP})/2.

10 The temperature Coefficient is calculated using following formula:

$$TC = \frac{B_{XPTA2} - B_{XPTA1}}{B_{XPT25} * (T_{A2} - T_{A1})} * 10^6, ppm/°C$$

where:

T_{A1} = -40°C, T_{A2} = 150°C, T₂₅ = 25°C

In case of magnetic Latch application: B_{XPTA1}, B_{XPTA2} OR B_{XPT25} = B_{OP}-B_{RP} at T_{A1}, T_{A2} OR T₂₅

In case of magnetic Switch application: B_{XPTA1}, B_{XPTA2} OR B_{XPT25} = B_{OP} OR B_{RP} at T_{A1}, T_{A2} OR T₂₅

11 Valid for 92232Lxx-AAA-0xx

12 Valid for 92232Lxx-AAA-2xx

MLX92232

End of Line programmable 3-Wire Hall Effect Latch/Switch

Datasheet

10 Programming parameters

Parameter	Symbol	Comments	Value	Units
B _{OP} programming resolution	B _{OPFINE}	Fine programming of the threshold B _{OP} (switch) and B _{LT} (Latch)	7	Bit
B _{OP} sub-range	B _{OPRANGE}	Selection of the appropriate switch sensor sub-range	2	Bit
B _{LT} sub-range	B _{OPRANGE}	Selection of the appropriate latch sensor sub-range	3	Bit
Programming hysteresis	B _{HYST}	Hysteresis can be fixed or proportional	4	Bit
Active Pole selection	B _{POLE}	Part can be programmed for south or north magnetic pole active	1	Bit
Output polarity selection	Pol _{OUT}	Selects direct or inverted output polarity	1	Bit
Switch/Latch function selection		Selects Latch or Switch sensor function	1	Bit
Melexis programmed ID	ID	A unique fixed ID implemented for device traceability, no overwriting allowed.	32	Bit

MLX92232

End of Line programmable 3-Wire Hall Effect Latch/Switch
Datasheet

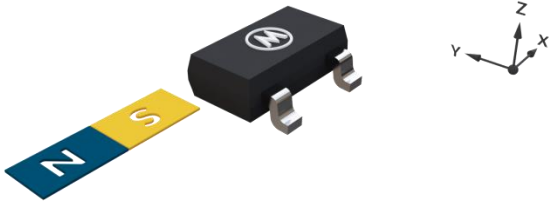

South active pole (IMC version)

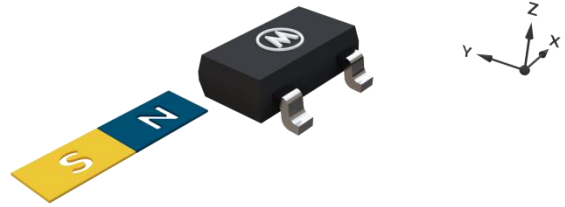

North active pole (IMC version)

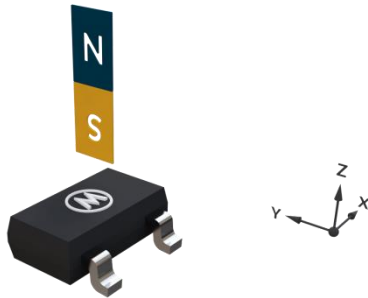

South active pole

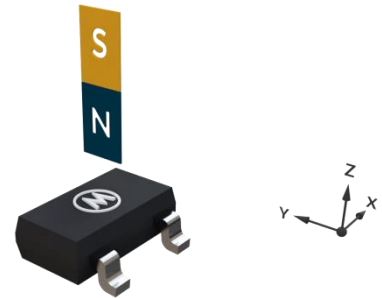

North active pole

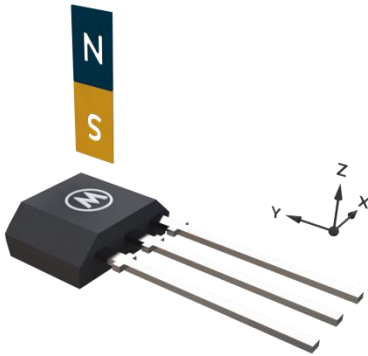

South active pole

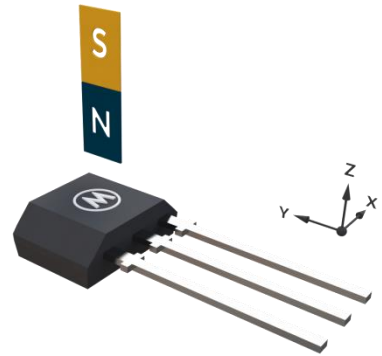

North active pole

MLX92232

End of Line programmable 3-Wire Hall Effect Latch/Switch

Datasheet

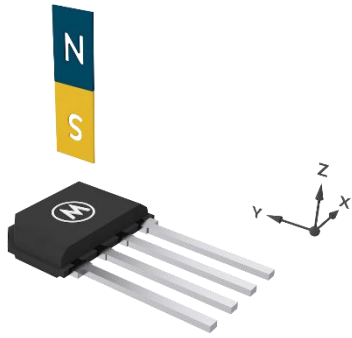

South pole active (VA package)

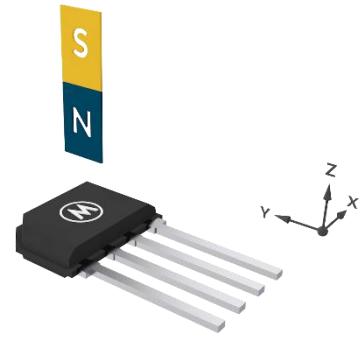

North pole active (VA package)

10.1 Latch Sensor

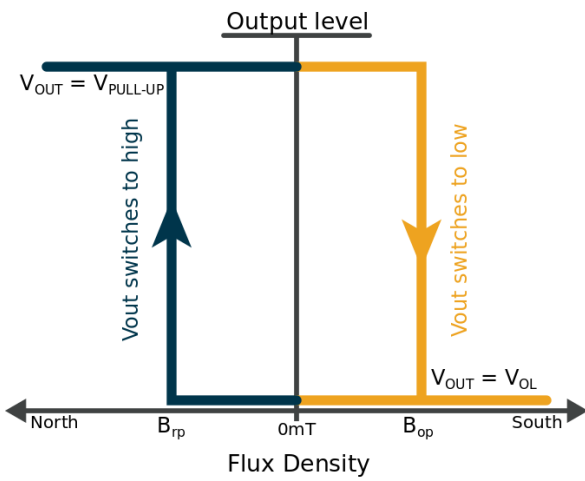

South Pole Active

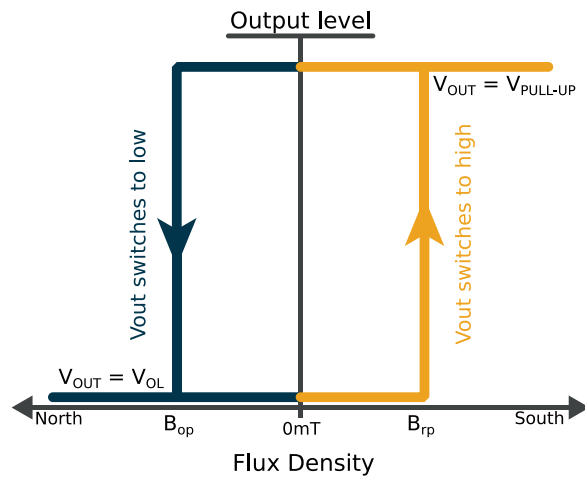

North Pole active

10.2 Switch Sensor

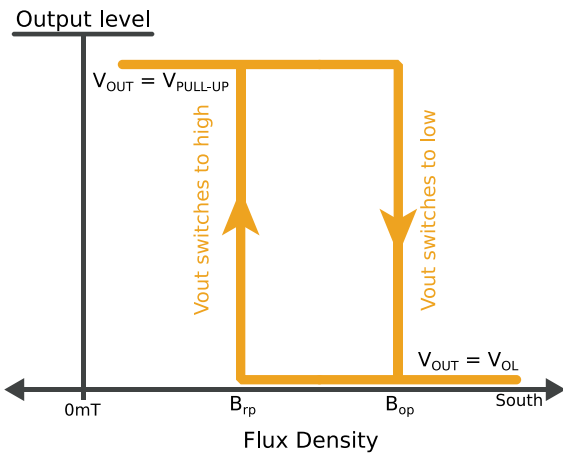

Direct South Active Pole

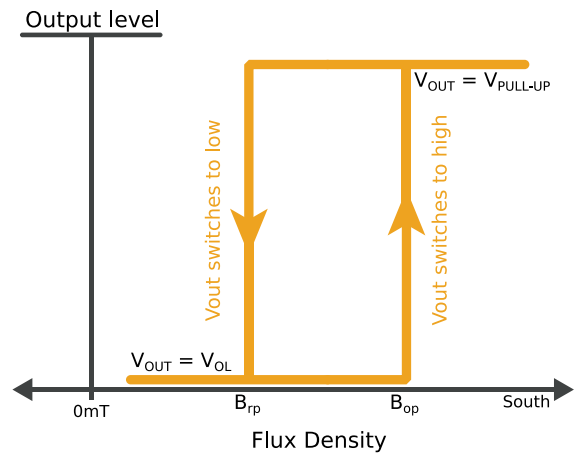

Inverted South Active Pole

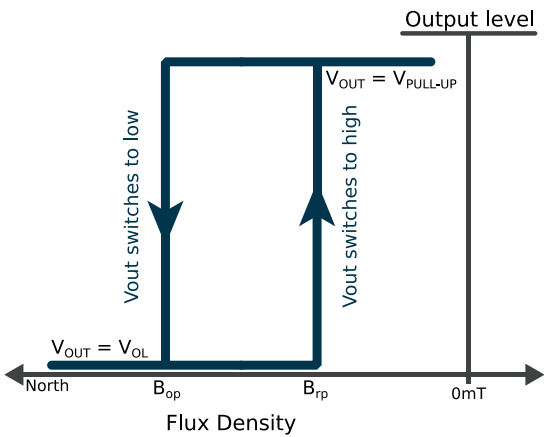

Direct North Active Pole

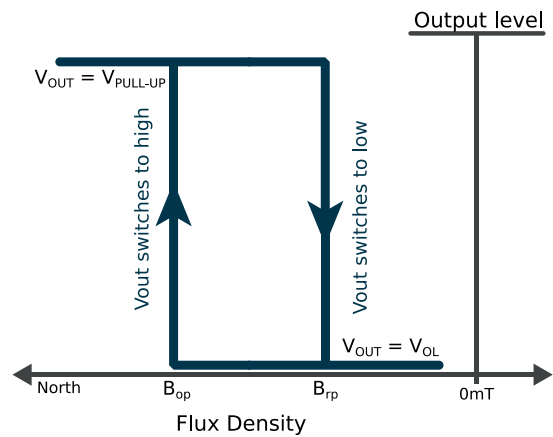

Inverted North Active Pole

MLX92232

End of Line programmable 3-Wire Hall Effect Latch/Switch

Datasheet

11 Application Information

11.1 Typical Three-Wire Application Circuit

11.1.1 92232LSE-AAA-xxx, 92232LUA-AAA-xxx

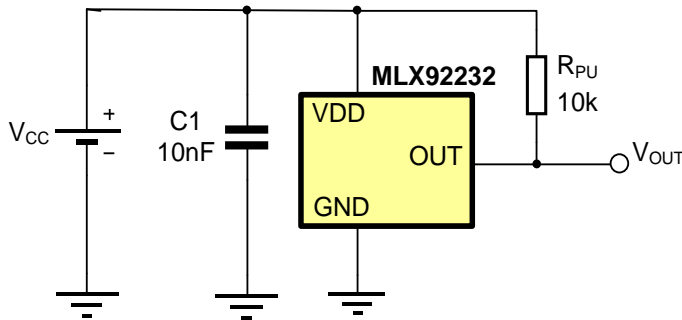

Notes:

1. For proper operation, a 10nF to 100nF bypass capacitor should be placed as close as possible to the V_{DD} and ground pin.
2. The pull-up resistor R_{PU} value should be chosen in to limit the current through the output pin below the maximum allowed continuous current for the device.
3. A capacitor connected to the output is not needed, because the output slope is generated internally.

11.1.2 92232LVA-AAA-xxx

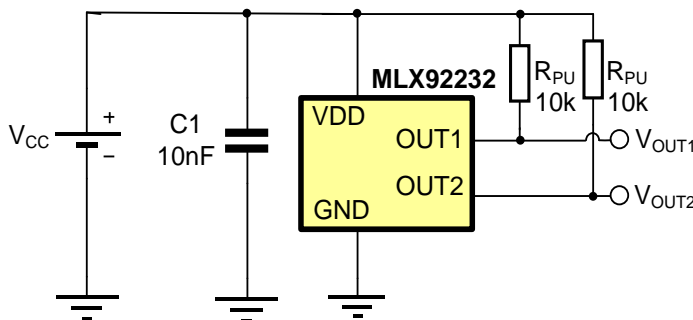

Notes:

1. For proper operation, a 10nF to 100nF bypass capacitor should be placed as close as possible to the V_{DD} and ground pin.
2. The pull-up resistors R_{PU} values should be chosen in to limit the current through the output pin below the maximum allowed continuous current for the device.
3. A capacitors connected to the outputs are not needed, because the output slope is generated internally.

11.2 Automotive and Harsh, Noisy Environments Three-Wire Circuit

11.2.1 92232LSE-AAA-xxx, 92232LUA-AAA-xxx

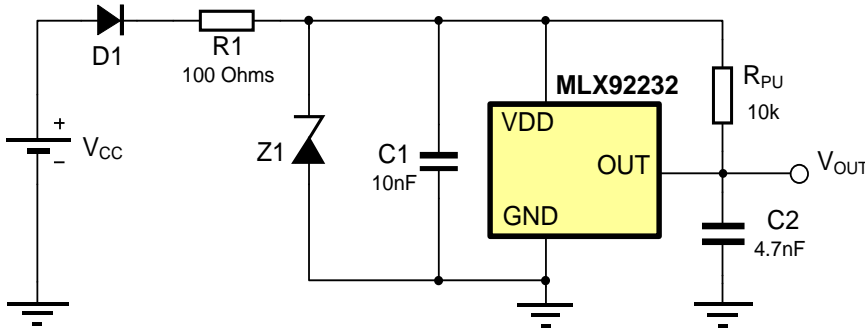

Notes:

- For proper operation, a 10nF to 100nF bypass capacitor should be placed as close as possible to the V_{DD} and ground pin.
- The device could tolerate negative voltage down to -24V, so if negative transients over supply line $V_{PEAK} < -30V$ are expected, usage of the diode D1 is recommended. Otherwise only R1 is sufficient.

When selecting the resistor R1, three points are important:

- the resistor has to limit I_{DD}/I_{DDREV} to 50mA maximum
- the resistor has to withstand the power dissipated in both over voltage conditions ($V_{R1}^2/R1$)
- the resulting device supply voltage V_{DD} has to be higher than V_{DD} min ($V_{DD} = V_{CC} - R1 \cdot I_{DD}$)

- The device could tolerate positive supply voltage up to +27V (until the maximum power dissipation is not exceeded), so if positive transients over supply line with $V_{PEAK} > 32V$ are expected, usage a zener diode Z1 is recommended. The R1-Z1 network should be sized to limit the voltage over the device below the maximum allowed.

11.2.2 92232LVA-AAA-xxx

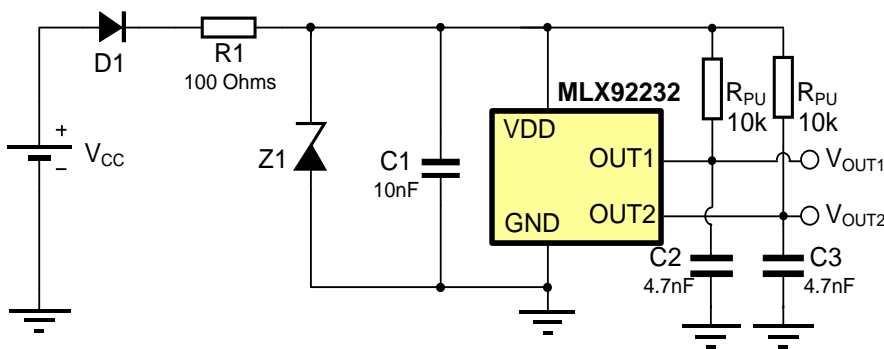

Notes:

- For proper operation, a 10nF to 100nF bypass capacitor should be placed as close as possible to the V_{DD} and ground pin.
- The device could tolerate negative voltage down to -24V, so if negative transients over supply line $V_{PEAK} < -30V$ are expected, usage of the diode D1 is recommended. Otherwise only R1 is sufficient.

When selecting the resistor R1, three points are important:

- the resistor has to limit I_{DD}/I_{DDREV} to 50mA maximum
- the resistor has to withstand the power dissipated in both over voltage conditions ($V_{R1}^2/R1$)
- the resulting device supply voltage V_{DD} has to be higher than V_{DD} min ($V_{DD} = V_{CC} - R1 \cdot I_{DD}$)

- The device could tolerate positive supply voltage up to +27V (until the maximum power dissipation is not exceeded), so if positive transients over supply line with $V_{PEAK} > 32V$ are expected, usage a zener diode Z1 is recommended. The R1-Z1 network should be sized to limit the voltage over the device below the maximum allowed.

MLX92232

End of Line programmable 3-Wire Hall Effect Latch/Switch

Datasheet

12 Package Information

12.1 TSOT-3L (SE Package)

12.1.1 TSOT-3L – Package dimensions

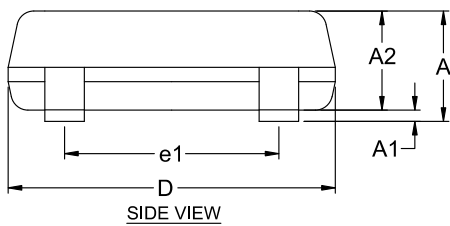
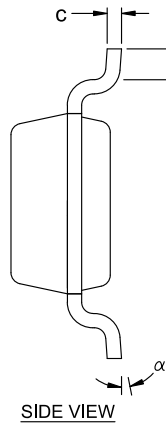
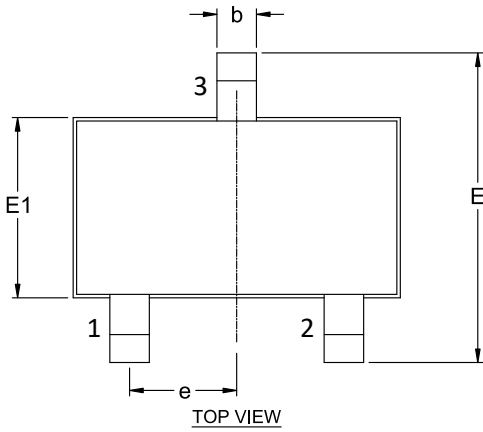

SYMBOL	MINIMUM	MAXIMUM
A	---	1.00
A1	0.025	0.10
A2	0.85	0.90
D	2.80	3.00
E	2.60	3.00
E1	1.50	1.70
L	0.30	0.50
b	0.30	0.45
c	0.10	0.20
e	0.95 BSC	
e1	1.90 BSC	
α	0°	8°

NOTE :

1. ALL DIMENSIONS IN MILLIMETERS (mm) UNLESS OTHERWISE STATED.
2. DIMENSION D DOES NOT INCLUDE MOLD FLASH OR PROTRUSIONS OF MAX 0.15 mm PER SIDE.
3. DIMENSION E DOES NOT INCLUDE MOLD FLASH OR PROTRUSIONS OF MAX 0.25 mm PER SIDE.
4. DIMENSION b DOES NOT INCLUDE DAMBAR PROTRUSION OF MAX 0.07 mm.
5. DIMENSION L IS THE LENGTH OF THE TERMINAL FOR SOLDERING TO A SUBSTRATE.
6. FORMED LEAD SHALL BE PLANAR WITH RESPECT TO ONE ANOTHER WITH 0.076 mm SEATING PLANE.

12.1.2 TSOT-3L – Sensitive spot

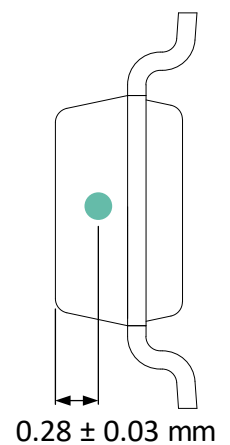
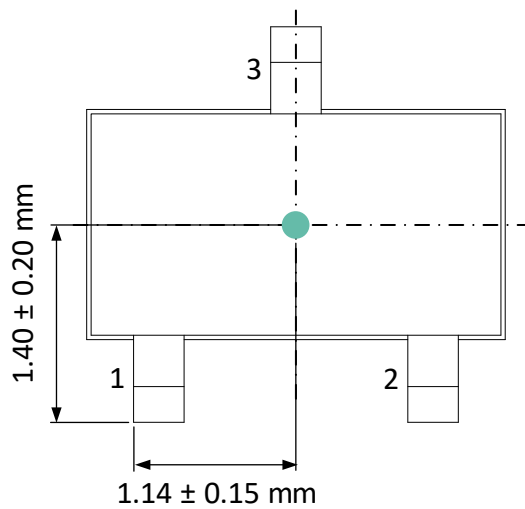
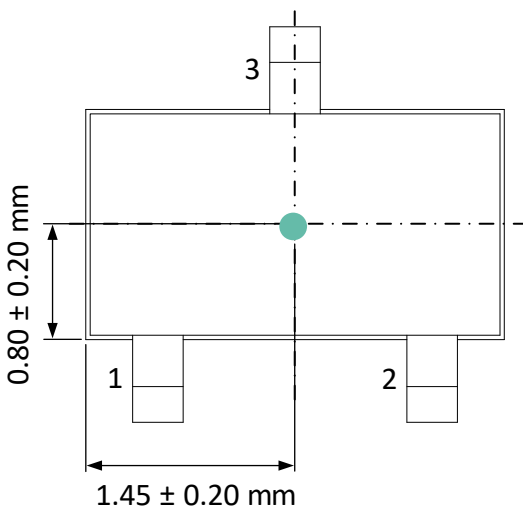

MLX92232

End of Line programmable 3-Wire Hall Effect Latch/Switch

Datasheet

12.1.3 TSOT-3L – Package marking / Pin definition

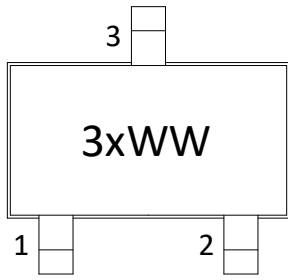

Top

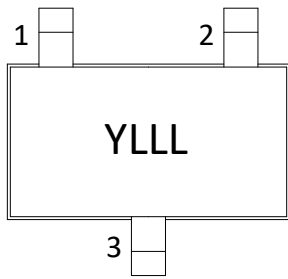
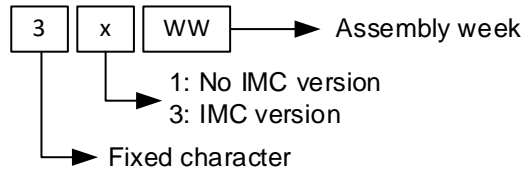

Bottom

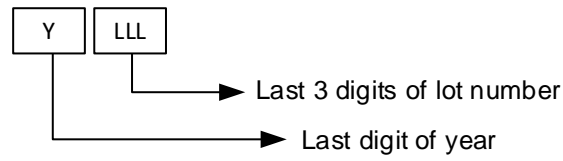

Pin #	Name	Type	Function
1	VDD	Supply	Supply Voltage pin
2	OUT	Out	Open drain output pin
3	GND	Ground	Ground pin

MLX92232

End of Line programmable 3-Wire Hall Effect Latch/Switch

Datasheet

12.2 TO92-3L (UA Package)

12.2.1 TO92-3L – Package dimensions

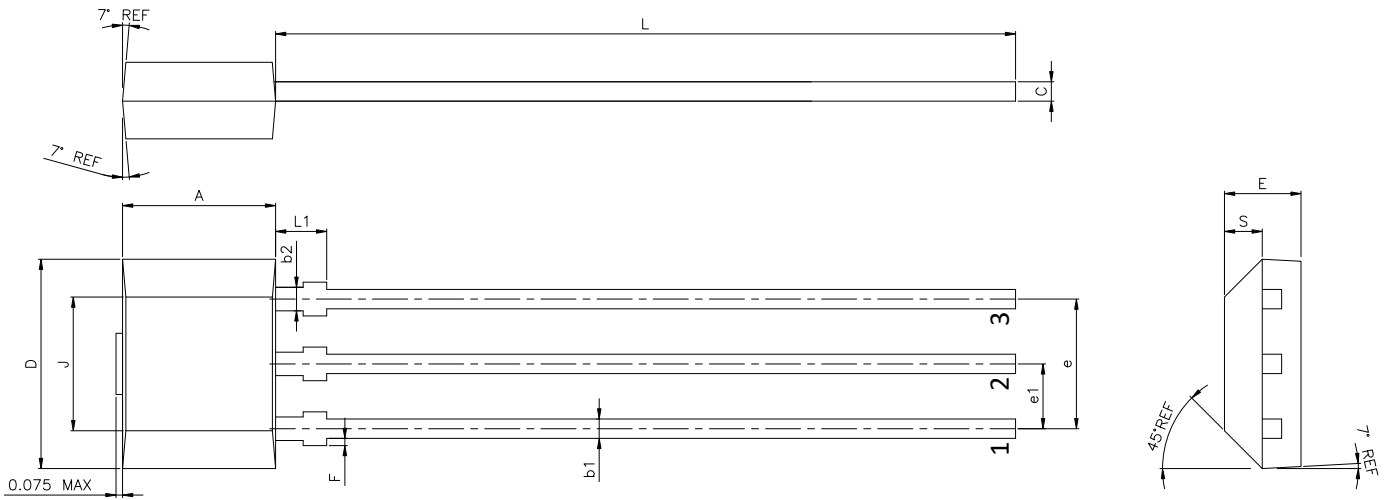

SYMBOL	MINIMUM	MAXIMUM
A	2.90	3.10
D	4.00	4.20
E	1.40	1.60
F	0.00	0.15
J	2.51	2.72
L	14.00	15.00
L1	0.90	1.10
S	0.63	0.84
b1	0.35	0.44
b2	0.43	0.52
c	0.35	0.44
e	2.51	2.57
e1	1.24	1.30

NOTES :

1. DIMENSIONS IN MILLIMETERS (mm) UNLESS NOTED OTHERWISE.
2. PACKAGE DIMENSIONS DO NOT INCLUDE MOLD FLASHES AND PROTRUSIONS.
3. DIMENSION A AND D DO NOT INCLUDE MOLD GATE AND SIDE FLASH (PROTRUSION) of MAXIMUM 0.127 mm PER SIDE.
4. THE LEADS MAY BE SLIGHTLY DEFORMED DURING TRANSPORTATION IF PACKED IN BULK (BAG), AFFECTING e1 DIMENSION. IT IS RECOMMENDED TO ORDER RADIAL TAPE (REEL OR AMMOPACK) IF SUCH DEFORMATION IS CRITICAL FOR THE LEAD FORMING PROCESS, EVEN IF MANUAL LOADING INTO THE TOOL IS FORESEEN.

12.2.2 TO92-3L – Sensitive spot

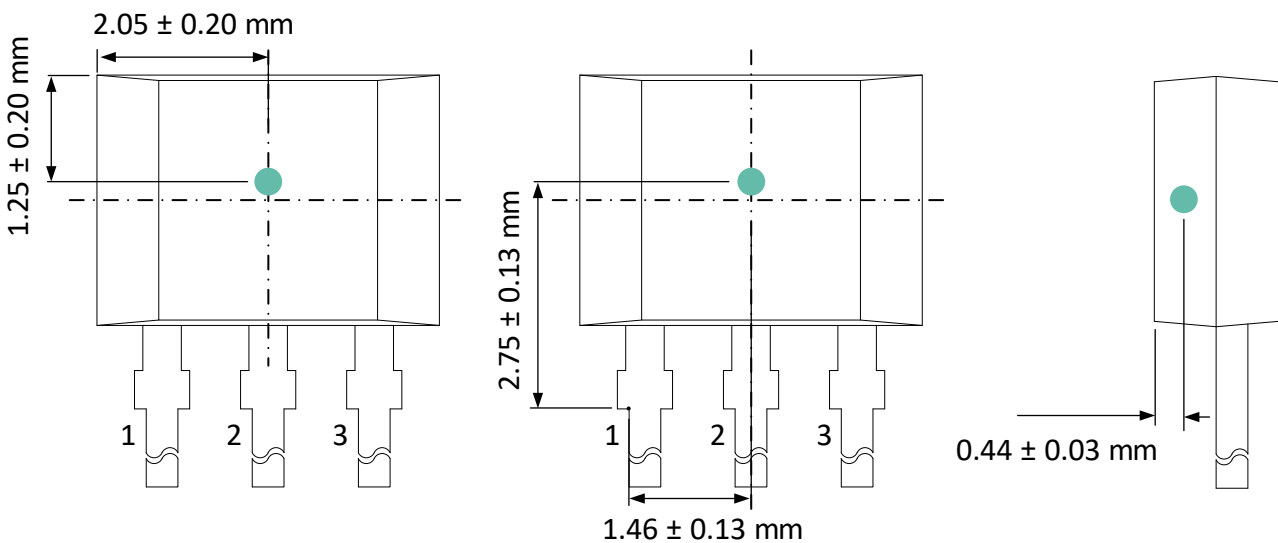

MLX92232

End of Line programmable 3-Wire Hall Effect Latch/Switch

Datasheet

12.2.3 TO92-3L – Package marking / Pin definition

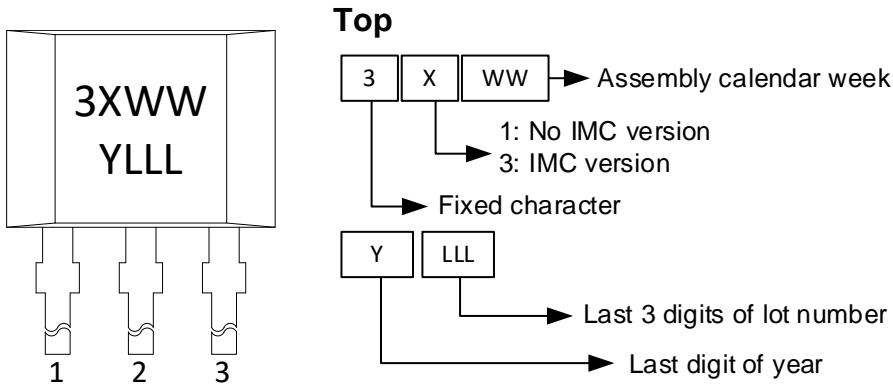

Pin #	Name	Type	Function
1	VDD	Supply	Supply Voltage pin
2	GND	Ground	Ground pin
3	OUT	Out	Open drain output pin

MLX92232

End of Line programmable 3-Wire Hall Effect Latch/Switch

Datasheet

12.3 VA Package

12.3.1 VA – Package dimensions

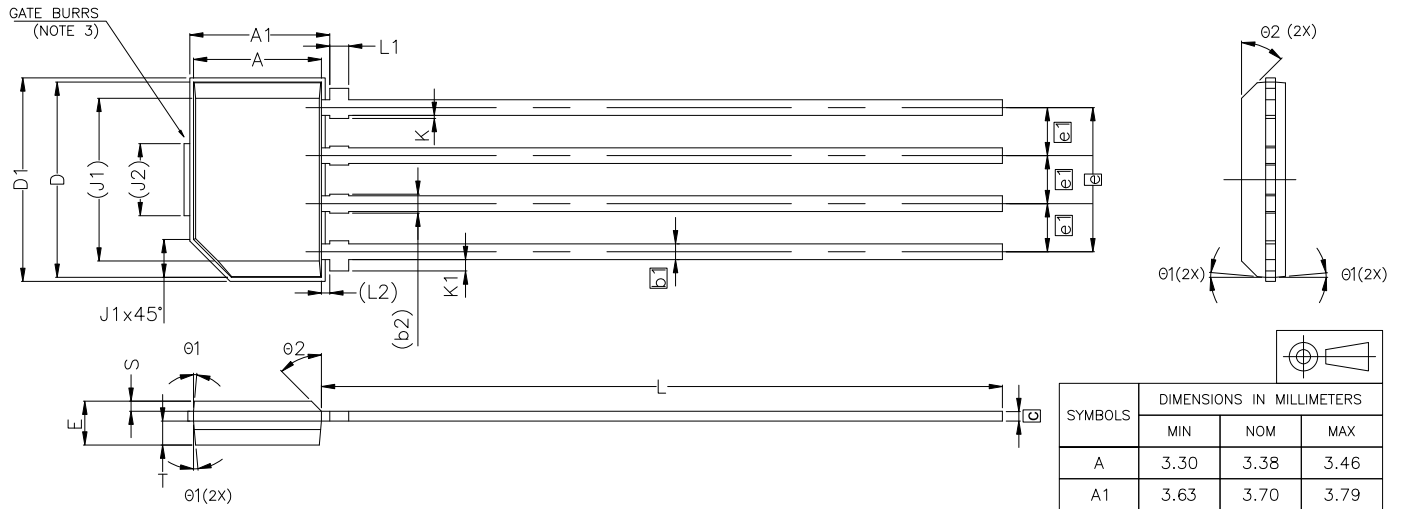

Note:

1. DIMENSIONS "A" AND "D" DO NOT INCLUDE MOLD FLASH, PROTRUSIONS AND GATE BURRS.
2. DIMENSIONS "A1" DOES NOT INCLUDE GATE BURRS BUT INCLUDES MOLD FLASH AT BOTH ENDS.
3. MOLD GATE BURRS SHALL NOT EXCEED 0.15 mm MEASURED FROM EDGE OF MOLD FLASH (FLANGE).
4. DIMENSION "D1" INCLUDES MOLD FLASH AT BOTH ENDS.
5. LEAD PLATING; MATTE TIN PLATING THICKNESS 7.62 – 15.42 um.

SYMBOLS	DIMENSIONS IN MILLIMETERS		
	MIN	NOM	MAX
A	3.30	3.38	3.46
A1	3.63	3.70	3.79
D	5.08	5.16	5.24
D1	5.33	5.38	5.43
E	1.10	---	1.20
J	4.10	4.30	4.50
J1	1.00 REF		
J2	1.906 REF		
K	0.00	---	0.15
K1	0.25	0.30	0.35
L	17.5	18.0	18.5
L1	0.45	0.50	0.55
L2	0.22 REF		
S	0.24	---	0.29
T	0.61	---	0.66
b1	0.42 BSC		
b2	0.50 REF		
c	0.25 BSC		
e	3.81 BSC		
e1	1.27 BSC		
Ø1	5° REF		
Ø2	45° REF		

MLX92232

End of Line programmable 3-Wire Hall Effect Latch/Switch

Datasheet

12.3.2 VA – Sensitive Spot

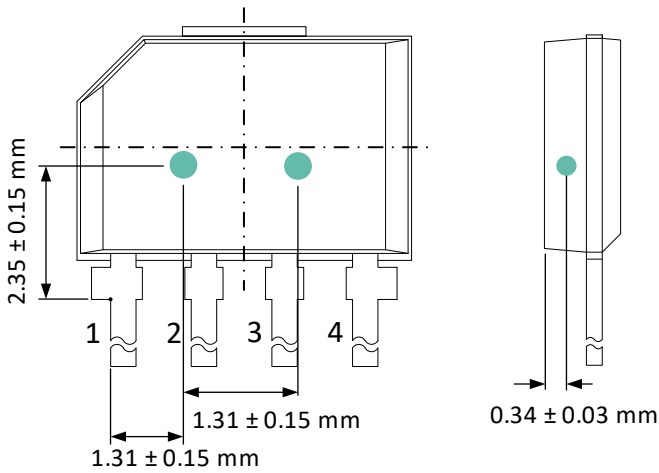

12.3.3 VA – Package marking / Pin definition

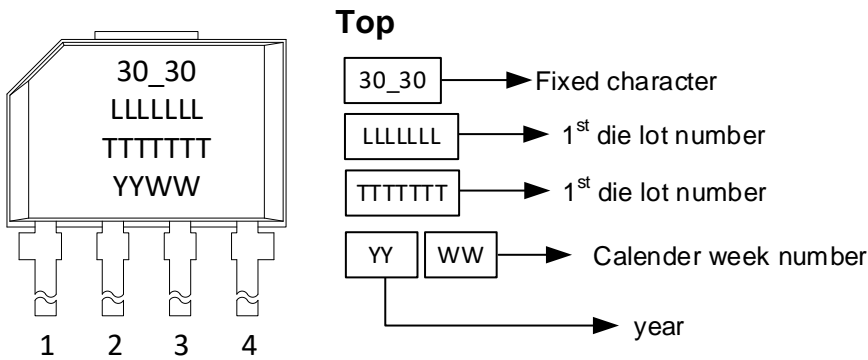

Pin #	Name	Type	Function
1	OUT1	Out	Open drain output pin
2	VDD	Supply	Supply Voltage pin
3	GND	Ground	Ground pin
4	OUT2	Out	Open drain output pin

13 IC handling and assembly

13.1 Storage and handling of plastic encapsulated ICs

Plastic encapsulated ICs shall be stored and handled according to their MSL categorization level (specified in the packing label) as per J-STD-033.

Electronic semiconductor products are sensitive to Electro Static Discharge (ESD). The component assembly shall be handled in EPA (Electrostatic Protected Area) as per ANSI S20.20

For more information refer to Melexis [Guidelines for storage and handling of plastic encapsulated ICs](#)⁽¹⁾

13.2 Assembly of encapsulated ICs

For Surface Mounted Devices (SMD, as defined according to JEDEC norms), the only applicable soldering method is reflow.

For Through Hole Devices (THD), the applicable soldering methods are reflow, wave, selective wave and robot point-to-point. THD lead pre-forming (cutting and/or bending) is applicable under strict compliance with Melexis [Guidelines for lead forming of SIP Hall Sensors](#)⁽¹⁾.

Melexis products soldering on PCB should be conducted according to the requirements of IPC/JEDEC and J-STD-001. Solder quality acceptance should follow the requirements of IPC-A-610.

For PCB-less assembly refer to the relevant application notes ⁽¹⁾ or contact Melexis.

Electrical resistance welding or laser welding can be applied to Melexis products in THD and specific PCB-less packages following the [Guidelines for welding of PCB-less devices](#)⁽¹⁾.

Environmental protection of customer assembly with Melexis products for harsh media application, is applicable by means of coating, potting or overmolding considering restrictions listed in the relevant application notes ⁽¹⁾

For other specific process, contact Melexis via www.melexis.com/technical-inquiry

13.3 Environment and sustainability

Melexis is contributing to global environmental conservation by promoting non-hazardous solutions. For more information on our environmental policy and declarations (RoHS, REACH...) visit www.melexis.com/environmental-forms-and-declarations

¹ www.melexis.com/ic-handling-and-assembly

14 Disclaimer

The content of this document is believed to be correct and accurate. However, the content of this document is furnished "as is" for informational use only and no representation, nor warranty is provided by Melexis about its accuracy, nor about the results of its implementation. Melexis assumes no responsibility or liability for any errors or inaccuracies that may appear in this document. Customer will follow the practices contained in this document under its sole responsibility. This documentation is in fact provided without warranty, term, or condition of any kind, either implied or expressed, including but not limited to warranties of merchantability, satisfactory quality, non-infringement, and fitness for purpose. Melexis, its employees and agents and its affiliates' and their employees and agents will not be responsible for any loss, however arising, from the use of, or reliance on this document. Notwithstanding the foregoing, contractual obligations expressly undertaken in writing by Melexis prevail over this disclaimer.

This document is subject to change without notice, and should not be construed as a commitment by Melexis. Therefore, before placing orders or prior to designing the product into a system, users or any third party should obtain the latest version of the relevant information. Users or any third party must determine the suitability of the product described in this document for its application, including the level of reliability required and determine whether it is fit for a particular purpose.

This document as well as the product here described may be subject to export control regulations. Be aware that export might require a prior authorization from competent authorities. The product is not designed, authorized or warranted to be suitable in applications requiring extended temperature range and/or unusual environmental requirements. High reliability applications, such as medical life-support or life-sustaining equipment or avionics application are specifically excluded by Melexis. The product may not be used for the following applications subject to export control regulations: the development, production, processing, operation, maintenance, storage, recognition or proliferation of:

- 1. chemical, biological or nuclear weapons, or for the development, production, maintenance or storage of missiles for such weapons;*
- 2. civil firearms, including spare parts or ammunition for such arms;*
- 3. defense related products, or other material for military use or for law enforcement;*
- 4. any applications that, alone or in combination with other goods, substances or organisms could cause serious harm to persons or goods and that can be used as a means of violence in an armed conflict or any similar violent situation.*

No license nor any other right or interest is granted to any of Melexis' or third party's intellectual property rights.

If this document is marked "restricted" or with similar words, or if in any case the content of this document is to be reasonably understood as being confidential, the recipient of this document shall not communicate, nor disclose to any third party, any part of the document without Melexis' express written consent. The recipient shall take all necessary measures to apply and preserve the confidential character of the document. In particular, the recipient shall (i) hold document in confidence with at least the same degree of care by which it maintains the confidentiality of its own proprietary and confidential information, but no less than reasonable care; (ii) restrict the disclosure of the document solely to its employees for the purpose for which this document was received, on a strictly need to know basis and providing that such persons to whom the document is disclosed are bound by confidentiality terms substantially similar to those in this disclaimer; (iii) use the document only in connection with the purpose for which this document was received, and reproduce document only to the extent necessary for such purposes; (iv) not use the document for commercial purposes or to the detriment of Melexis or its customers. The confidentiality obligations set forth in this disclaimer will have indefinite duration and in any case they will be effective for no less than 10 years from the receipt of this document.

This disclaimer will be governed by and construed in accordance with Belgian law and any disputes relating to this disclaimer will be subject to the exclusive jurisdiction of the courts of Brussels, Belgium.

The invalidity or ineffectiveness of any of the provisions of this disclaimer does not affect the validity or effectiveness of the other provisions. The previous versions of this document are repealed.

*Melexis © - No part of this document may be reproduced without the prior written consent of Melexis. (2024)
IATF 16949 and ISO 14001 Certified*

For the latest revision of this document, visit www.melexis.com/MLX92232

Happy to help you! www.melexis.com/contact